

INSTALLATION FOR CEDAR BREATHER SHAKE INSTALLATION

NOTE: Recommended on a 4/12 roof slope or greater.

Step 1:

Install plywood deck onto roof rafters.

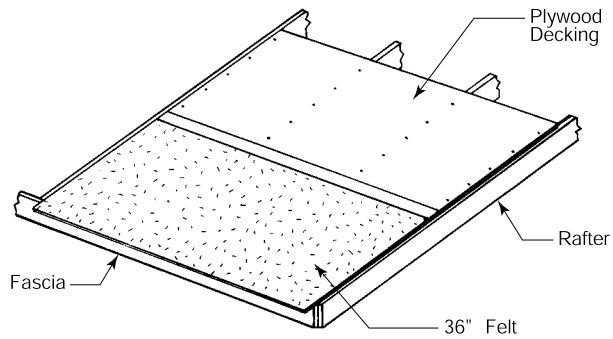

Step 2:

Install 36" of 30 lb. roofing felt for eave protection extending 1/4" beyond edge of roof deck.

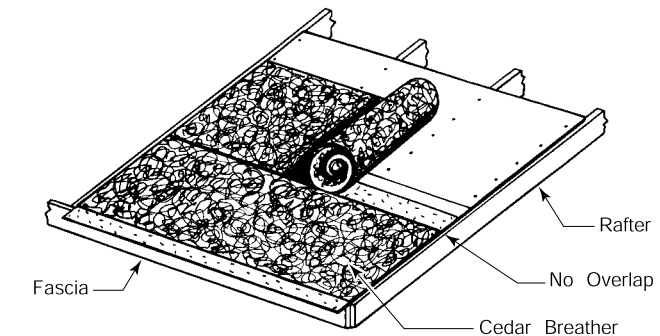

Step 3:

Tack down Cedar Breather. One tack (or nail) approximately every 3 square feet is adequate. Install with dimples down to present the flat side as the nailing surface.

Do not lap layers of Cedar Breather. Each course should butt against previous course.

Work from fascia to ridge just ahead of shake and felt installation to avoid walking directly on Cedar Breather (may be slippery, especially when wet).

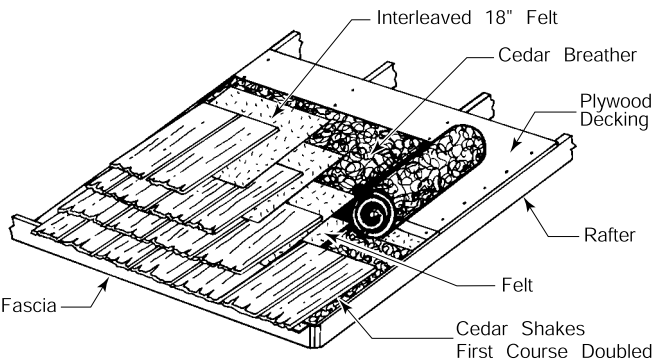

Step 4:

An 18" wide strip of 30 lb. roofing felt should be laid over the top portion of the shakes and extend onto the Cedar Breather. The bottom edge of the felt should be positioned above the butt of the shake at a distance equal to twice the weather exposure per manufacturer's installation instructions. Utilize a nail length that will allow for 3/4" penetration into sheathing. Allow 1/4" for Cedar Breather thickness.



For additional information call:

800-346-7655